

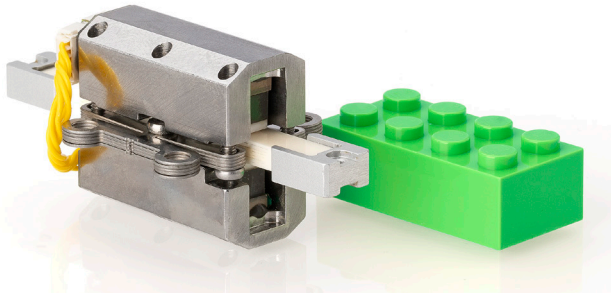

Piezo LEGS® LT40A Linear Actuator



Key features

- 40 N force
- Sub nanometer precision
- Direct drive and no backlash
- No power draw in hold position
- Unparalleled size to force ratio

Product Description

The drive technology employed is direct, eliminating the need for gears or lead screws to generate linear motion. The motor operates through micro-stepping, dividing a complete waveform-step into sub nanometer-sized increments. Speed ranges from nanometers per second to millimeters per second and can be seamlessly controlled within the entire dynamic

range. Additionally, it offers high force output within a compact body, achieving a stall force of 40N and a weight of only 61 grams.

The motor has no backlash.

Available in three versions: Standard stainless steel for general environments (A), Vacuum version (C) and Non-magnetic vacuum version (D). Each version is offered with M1 or M2 mounting.

Product Dimensions (mm)

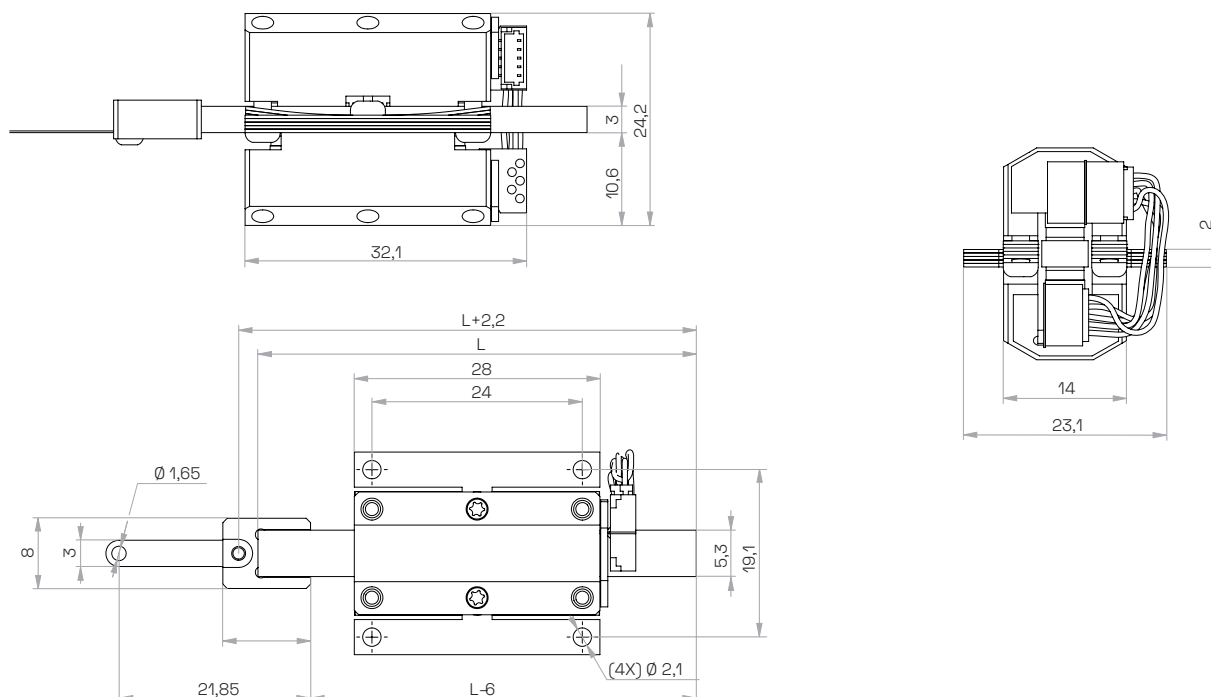

Piezo LEGS® LT40A Piezo Linear Actuator Specifications

TYPE	STANDARD (A)
Maximum stroke	67 mm
Maximum speed (driver dependent)	12 mm/s
Minimum speed (driver dependent)	1 nm/s
Max operating frequency	3 kHz
Minimal incremental motion	0.5 nm
Stall force	40 N
Holding force	>40 N
Vacuum	No
Non-magnetic	No
Operating voltage	42-48 V
Power consumption	20 mW/Hz
Mechanical size L x H x D	32.1 x 24.2 x 23.1 mm
Weight with 50 mm drive rod	61 g
Material in motor housing	Stainless steel
Operating temperature (recommended)	-20 to +70°C
Storage temperature	-50 to 85°C

All specifications are subject to change without notice. Latest data sheets are available on acuvi.com

Controllers

PMD301 1-axis micro-step driver/controller - max 3 kHz, RS485 or USB
PMD401 1-axis micro-step driver/controller - stackable PCB, max 1.5 kHz, RS485 or SPI

Accessories

Starter Kit PMD401 controller, motor cables, USB-to-RS485 cable, and power supply
Piezo Drive lab software downloadable from acuvi.com

